

VALMATIC®

Proven Design

Preferred Features

Advanced Technology

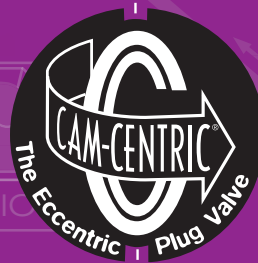

Cam-Centric®
Plug Valves



www.valmatic.com

Meets AWWA C517
NSF/ANSI 372 Certified

Feature Highlights

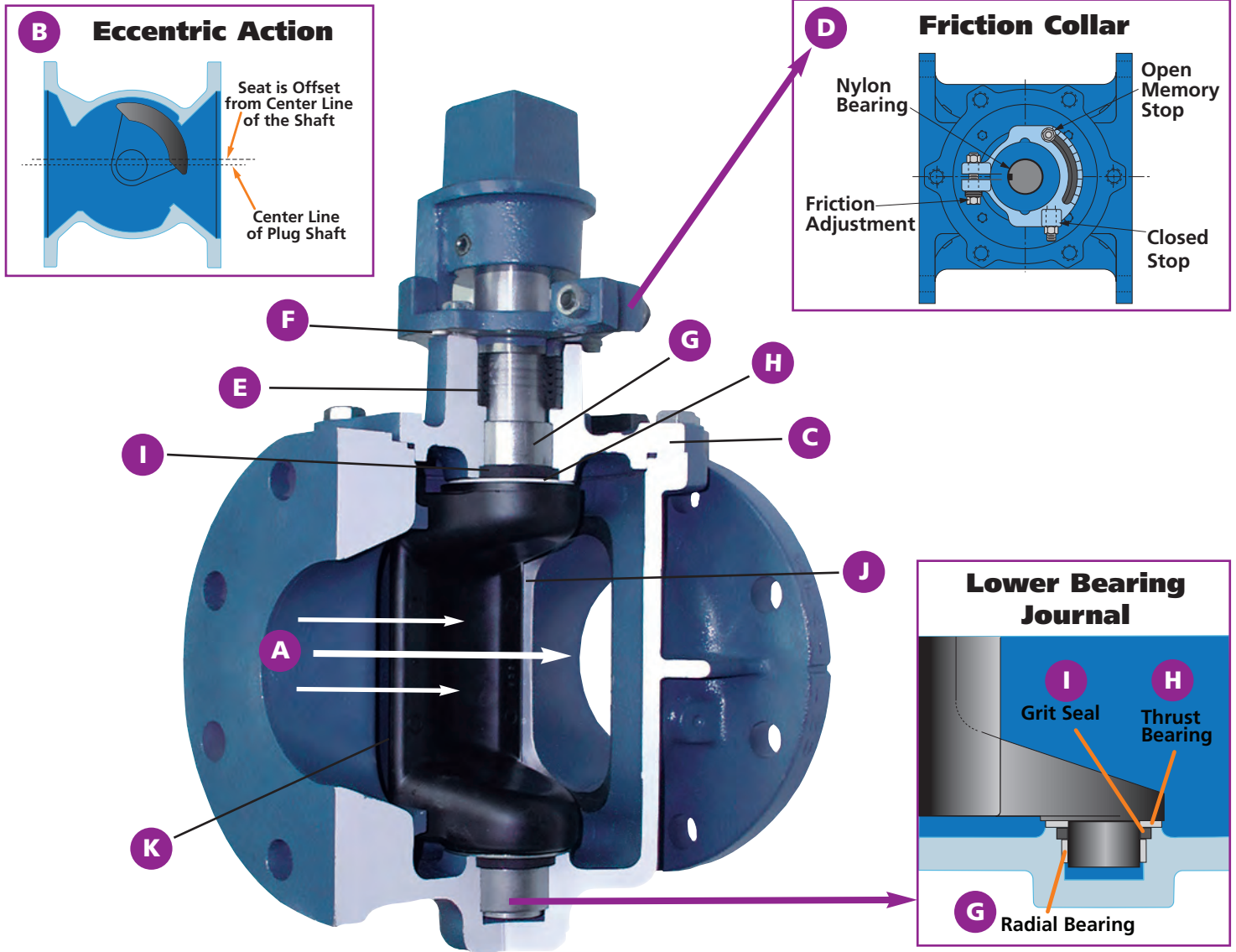

A. Non-Clog Design

The unrestricted flow area combined with smooth streamline contouring allows passage of large solids to prevent potential clogging and provide low headloss.

B. Eccentric Action

Provides positive shut off with wear resistant action and low torque.

C. Full Top Access Cover

Provides accessibility for inspection without removal of the valve from the line.

D. Friction Collar with Memory Stop

Secures valve plug in any position and includes a nylon bearing for ease of operation.

E. V-Type Packing

Field adjustable and replaceable without removal of worm gear or motor actuators.

F. Removable POP™ Shims

Packing Overload Protection Shims protect packing by preventing overload during field adjustment.

G. Radial Bearings

Heavy Duty, T316 Stainless Steel, Permanently Lubricated.

H. Thrust Bearing

Upper: PTFE - Provides ease of actuation during operating conditions.
Lower: Stainless Steel - Prevents wear to plug and Grit-Guard.

I. Grit-Guard™ Shaft Seal

The *Val-Matic Exclusive* Grit-Guard™ shaft seal extends packing and bearing life by minimizing contact with abrasive line media.

J. Seat

Welded overlay of 95% pure nickel applied directly to the body using a state-of-the-art robotic welding system for a consistent, high quality weld. Machined and ground to a smooth finish.

K. Plug

Fully rubber encapsulated molded plug eliminates exposed surfaces preventing corrosion and delamination.

Proven Design

With installations worldwide, the Val-Matic Cam-Centric® Plug Valve has proven itself as the preferred valve for wastewater, industrial waste and process applications. The Cam-Centric® Plug Valve is a ¼ turn eccentric plug valve allowing cost effective, low torque actuation for pump control, shut-off and throttling service. The valve's eccentric action rotates the plug in and out of the seated position with minimal contact, thereby preventing high torque and wear to the valve seat and plug. The combination of the eccentric action, stainless steel bearings, Grit-Guard™ seals and heavy duty nickel seat assures long life with minimal maintenance.

Preferred Features

The Cam-Centric® Plug Valve features a shaft sealing system that utilizes V-Type packing, a packing follower and a Grit-Guard™ seal for ease of maintenance and to reduce wear. The Grit-Guard™ seals reduce wear by preventing grit and media from reaching the bearings and packing to prevent plug lock up. The seals are standard in both the upper and lower journals (Figures 1 & 2). To prevent the packing from being over tightened, the shaft seal incorporates POP™ (Packing Overload Protection) Shims. The packing is easily adjusted by removing the POP™ shims as necessary utilizing the pull tab feature (Figure 1). Adjustment or

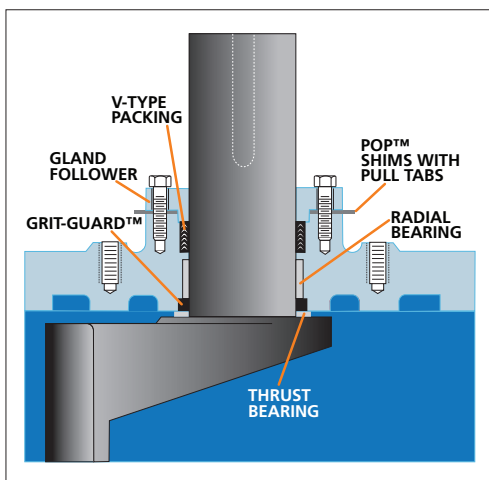

Figure 1. Upper Bearing Journal

replacement of the V-Type packing can be done without removal of the gear, motor or cylinder actuator.

The Cam-Centric® bearing package consists of permanently lubricated, T316 stainless steel radial bearings in both the upper and lower journals. The upper thrust bearing is made of Teflon and the lower thrust bearing is T316 stainless steel. The bearings

are protected from grit related wear by the Grit-Guard™ seals (Figures 1 & 2).

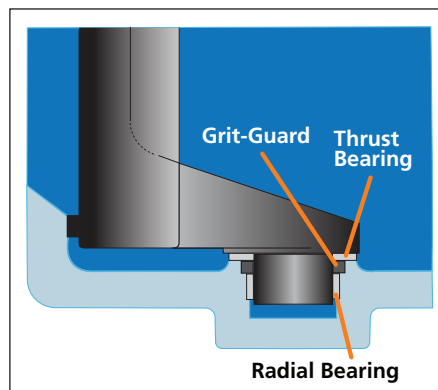

Figure 2. Lower Bearing Journal

The Cam-Centric® Plug Valve utilizes a totally encapsulated molded plug to protect exposure to corrosion and delamination in severe abrasive applications.



Figure 3. Robotic welding of nickel seat

The valve seat is a welded overlay of 95% pure nickel applied directly to the body on a machined surface using a state-of-the-art robotic welding system for a consistent, high quality weld (Figure 3).

Advanced Technology

Incorporating the latest in valve technology assures a high-quality valve that will provide long service. The design process utilized solid Modeling and Finite Element Analysis (FEA) of the key structural components. Flow and torque data was derived from flow tests, mathematical models and Computational Fluid Dynamics (CFD). Manufacturing technology uses automated process control in the foundry and ISO 9001 controlled manufacturing processes. Every valve is tested in accordance with AWWA C517 and MSS SP-108 on automated hydraulic test rigs with gauges calibrated per ISO standards.

Actuation

The Cam-Centric® Plug Valve is available with a wide range of actuation options, from simple lever operation to advanced pump control systems. Options include 2" operator nuts, worm gears, chainwheels, electric motor and cylinder actuation. A wide variety of accessories such as floor stands and extended bon-

nets are also available (see accessories on page 7). Val-Matic Engineering personnel work closely with cylinder and electric actuation manufacturers to assure actuator/valve compatibility. This assures the actuator you specify will deliver the performance you expect when utilized with a Cam-Centric® Plug Valve.



Direct Nut operated valve with memory stop:

- Adjustable open memory stop for system balancing
- Adjustable close stop
- Adjustable friction collar
- For use with lever accessories



Val-Matic Worm Gears:

- Heavy Duty, totally enclosed and sealed
- For above ground and buried service applications
- Bronze radial bearings and roller thrust bearings provide smooth operations and extended life

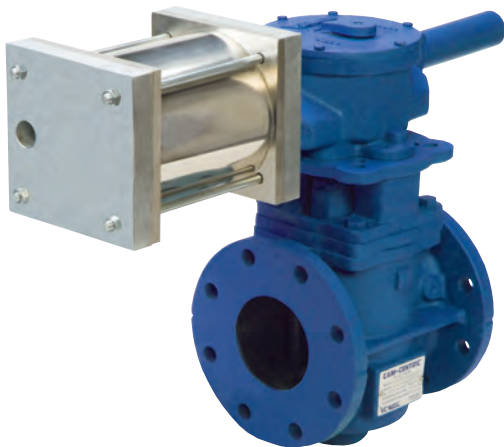

Val-Matic Cylinder Actuation:

- Compliance with AWWA C541 for Power Actuation
- Pneumatic/Hydraulic
- Single Acting or Double Acting
- Fail Open/Closed for power failure
- Modulating Service
- Throttling Service
- Limit Switches, Solenoid Valves, Positioners
- Manual Overrides
- Pump Control



Electric Actuation:

- 110 Single Phase, 230/460 Three Phase
- Compliance with AWWA C542 for Power Actuation
- Modulating Service
- Throttling Service
- Remote push button control and indication
- Torque Switches, Limit Switches
- De-clutchable handwheels
- Available from a wide variety of manufacturers

Worm Gear Features

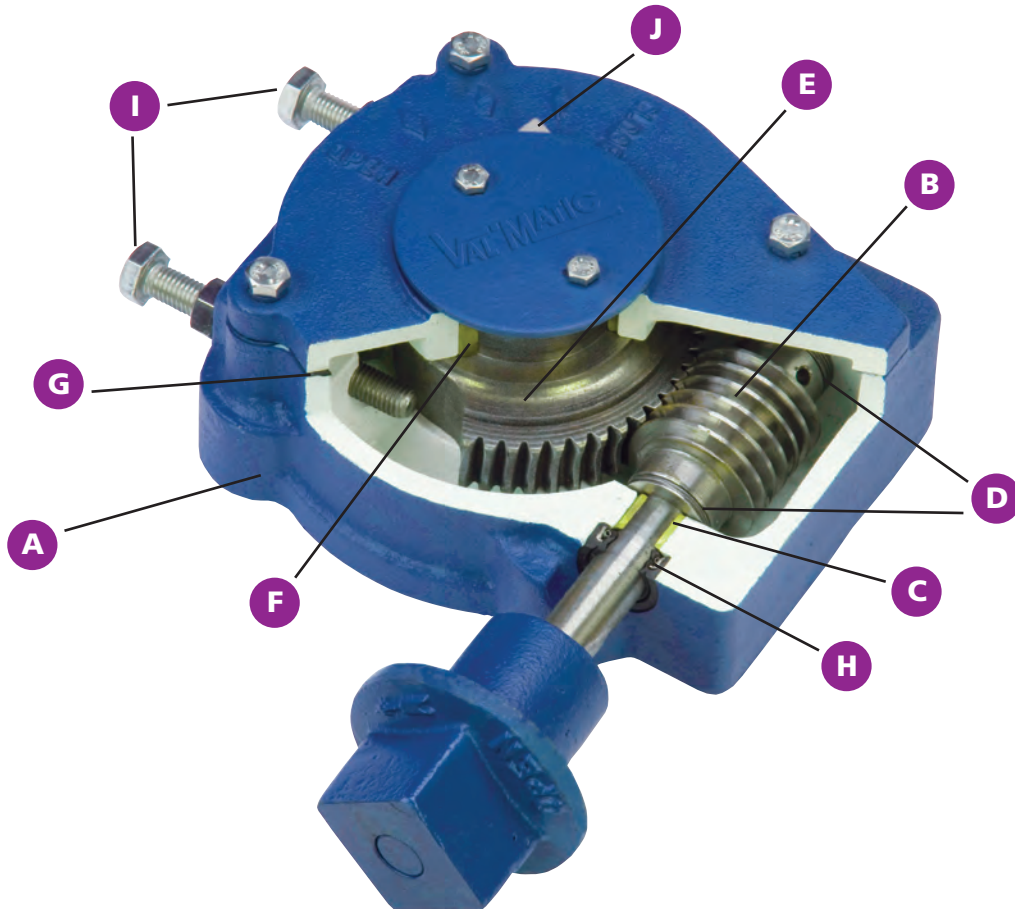

Val-Matic Worm Gear

A valve actuator must perform to the same level as the valve. The Val-Matic worm gear is designed and built to provide the same long term service as our Cam-Centric® Plug Valve. The exclusive bearing package in the worm gear includes four bronze sleeve bearings and two roller thrust bearings. This exclusive package assures smooth operation and long life regardless of the valve's orientation or application. The ductile iron segment gear coupled with the upper and lower bronze radial bearings exceed the requirements of AWWA C517 for strength and durability. All worm gears are designed to exceed, a rim pull of 200 pounds on handwheels and input torques of 300 foot pounds for operator nuts without damage. Buried service worm gears are grease packed, sealed and include stainless steel shafts. Worm gears can be provided with handwheels, chainwheels or 2" operator nuts.

A. Housing

Heavy duty, totally enclosed and sealed.

B. Worm

Hardened steel for durability and long life.

C. Radial Shaft Bearings

Bronze shaft bearings extend life and provide ease of operation (rear shaft bearing not visible).

D. Roller Thrust Bearings

Provides smooth operation and extends life.

E. Segment Gear

Heavy duty ductile iron for high strength. Provided with precision bore and keyway for connection to the valve shaft in multiple positions.

F. Segment Gear Radial Bearings

Upper and lower bronze bearings provide ease of operation and extend life (lower bearing not visible).

G. Cover Gasket

Seals housing and prevents foreign material from entering actuator and prevents loss of grease.

H. Shaft Seal

Prevents foreign material from entering the actuator.

I. External Stops

Both open and closed stops are external and easily adjustable.

J. Position Indicator

Displays precise plug position on above ground service.

Headloss Charts

Standard Port

CUBIC METERS PER HOUR

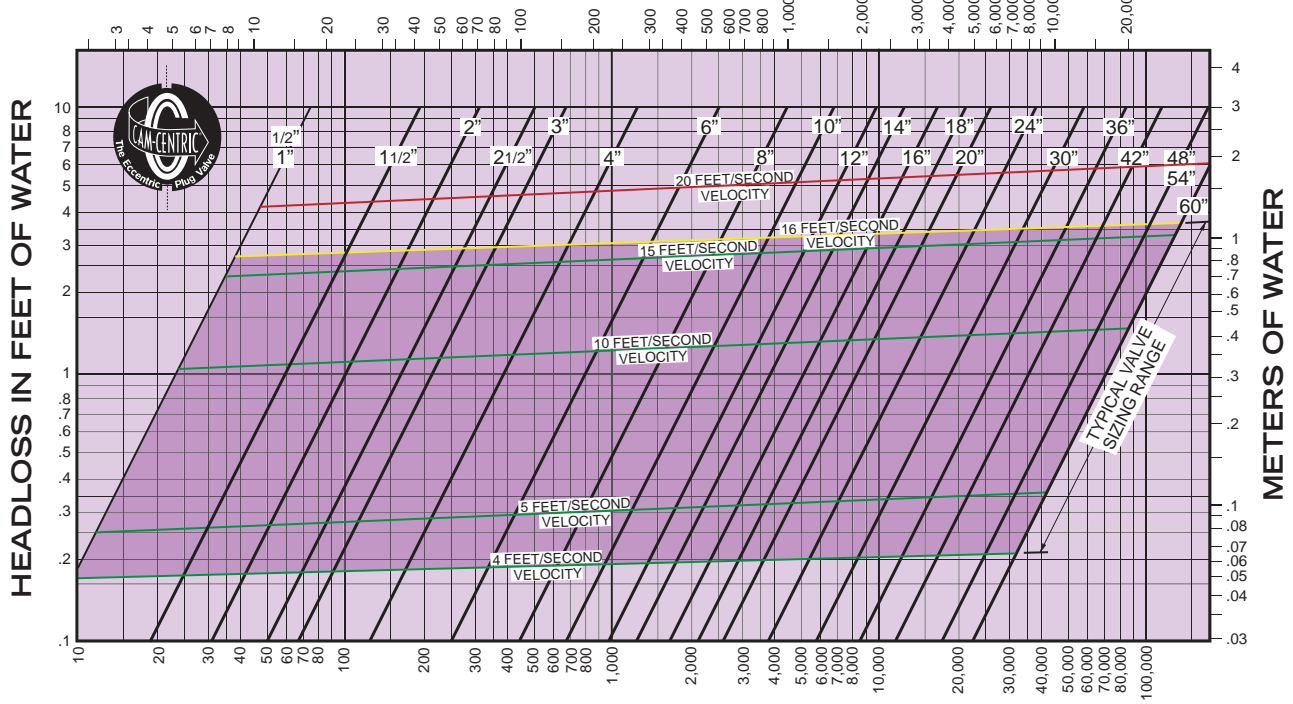

Flow Coefficients

FLOW OF WATER IN GALLONS PER MINUTE

Size	1/2-1	1 1/2	2	2 1/2	3	4	6	8	10	12	14	16	18	20	24	30	36	42	48-54	60
Cv	37	94	150	240	320	570	1200	2070	3250	4750	6150	8050	10,200	12,600	18,100	28,300	40,700	55,400	91,650	113,000

100% Port

CUBIC METERS PER HOUR

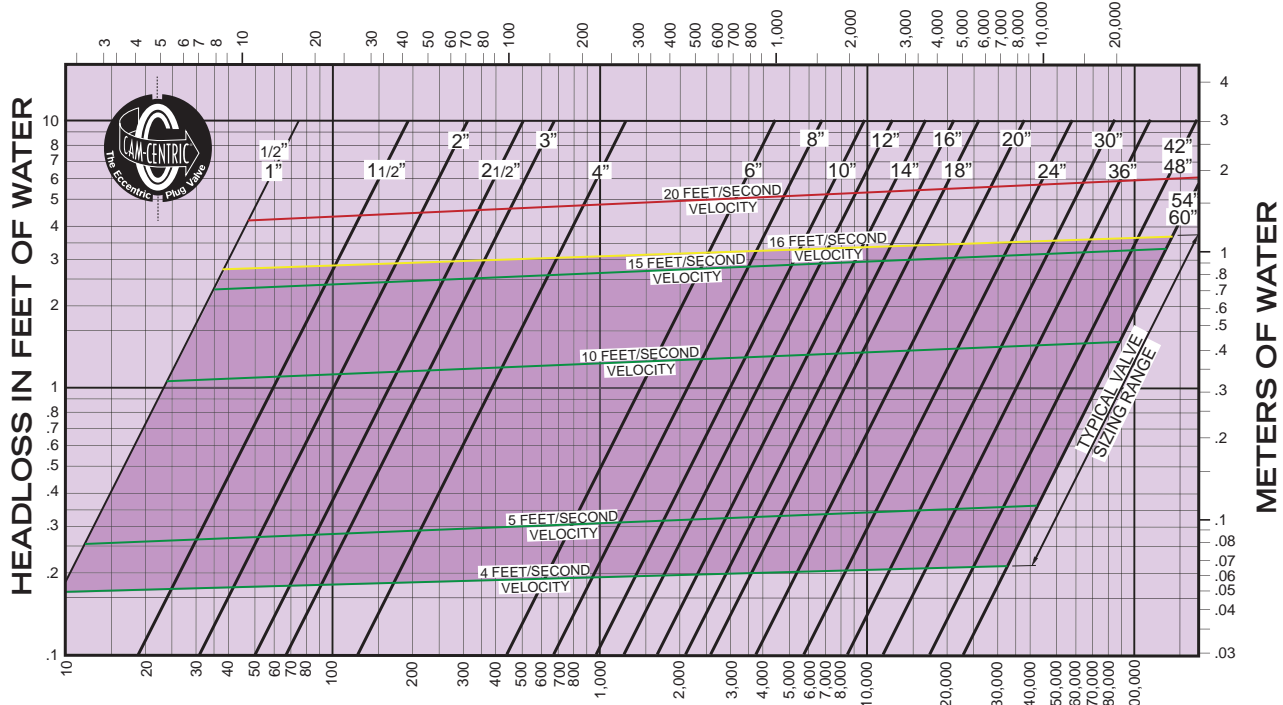

Flow Coefficients

FLOW OF WATER IN GALLONS PER MINUTE

Size	1/2-1	1 1/2	2	2 1/2	3	4	6	8	10	12	14	16	18	20	24	30	36	42-48	54-60
Cv	37	94	150	240	320	570	2070	3250	4750	6150	8050	10,200	12,600	18,100	28,300	40,700	55,400	91,650	113,000

PRESSURE RATINGS

MAXIMUM PRESSURE RATINGS			
SERIES	CONNECTION	SIZE RANGE	CWP (psig)
5400	ANSI Class 125 Flanged 4-Way	4" - 12"	175
5500	ANSI Class 125 Flanged 3-Way	4" - 12"	175
5600R	ANSI Class 125 Flanged 100% Port	4" - 10"	175
		12" - 48"	150
5700R	AWWA C111 Mechanical Joint 100% Port	4" - 10"	175
		12" - 48"	150
5800RTL	ASME NPT Threaded	1/2" - 2"	175
5800R	ANSI Class 125 Flanged	2" - 12"	175
		14" - 54"	150
5800HP	ANSI Class 125 Flanged High Pressure	3" - 24"	250
5900R	AWWA C111 Mechanical Joint	3" - 12"	175
		14" - 48"	150
5900HP	AWWA C111 Mechanical Joint High Pressure	3" - 48"	250

MATERIALS OF CONSTRUCTION

COMPONENT	STANDARD
Body (5600R, 5700R, 5800R, 5900R)	Cast Iron ASTM A126, Class B
Body (5400, 5500, 5800HP, 5900HP)	Ductile Iron ASTM A536, Grade 65-45-12
Plug (5600R, 5700R, 5800R, 5900R)	Cast Iron ASTM A126, Class B, Buna-N Encapsulated, ASTM D2000
Plug (5400, 5500, 5800HP, 5900HP)	Ductile Iron ASTM A536, Grade 65-45-12, Buna-N Encapsulated, ASTM D2000
Radial Shaft Bearings	T316 Stainless Steel
Top Thrust Bearing	Teflon
Bottom Thrust Bearing	T316 Stainless Steel
Available Coatings	Two-Part Epoxy, Fusion Bonded Epoxy, Glass Lining, Rubber Lining

Accessories

Space limitations and application specifics often require special accessories. In addition to those shown below, Val-Matic offers a wide range of accessories to meet your application requirements.

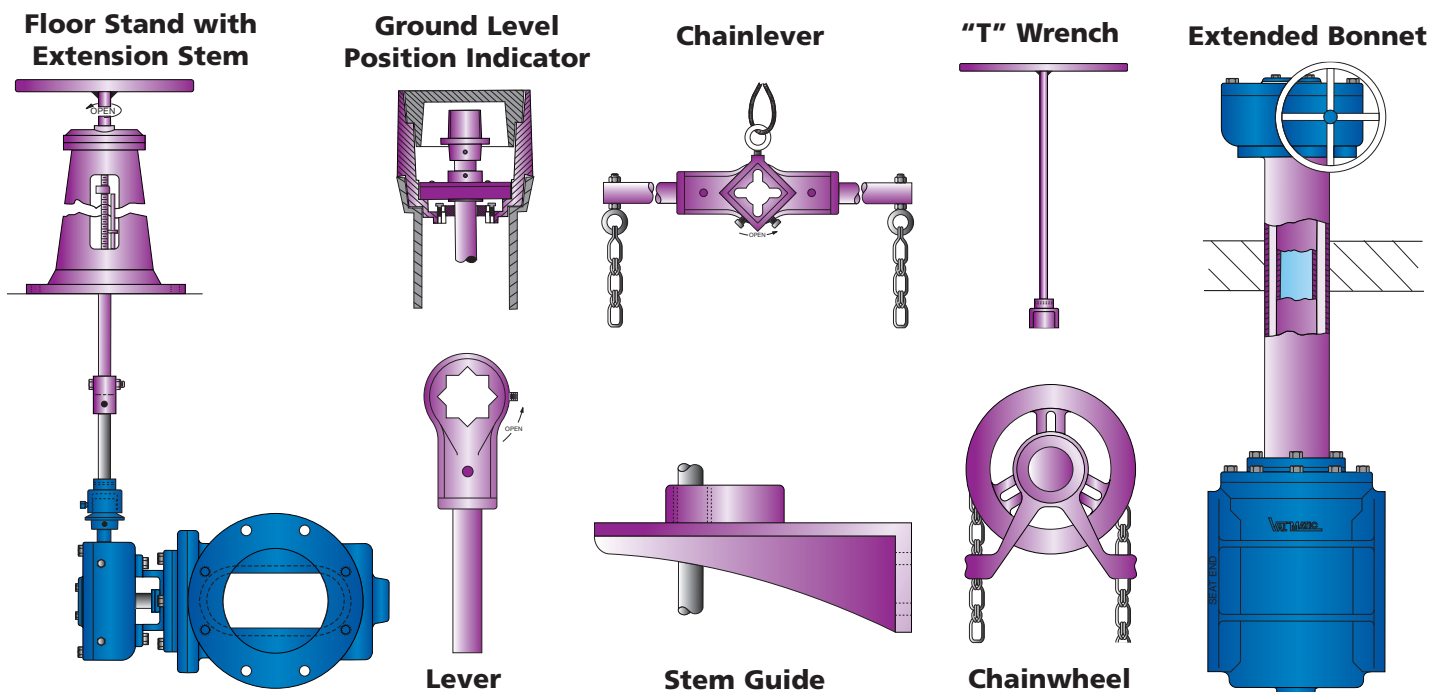

Installation Dimensions

Direct Nut Operated

Flanged, Mechanical Joint, Threaded End Connections

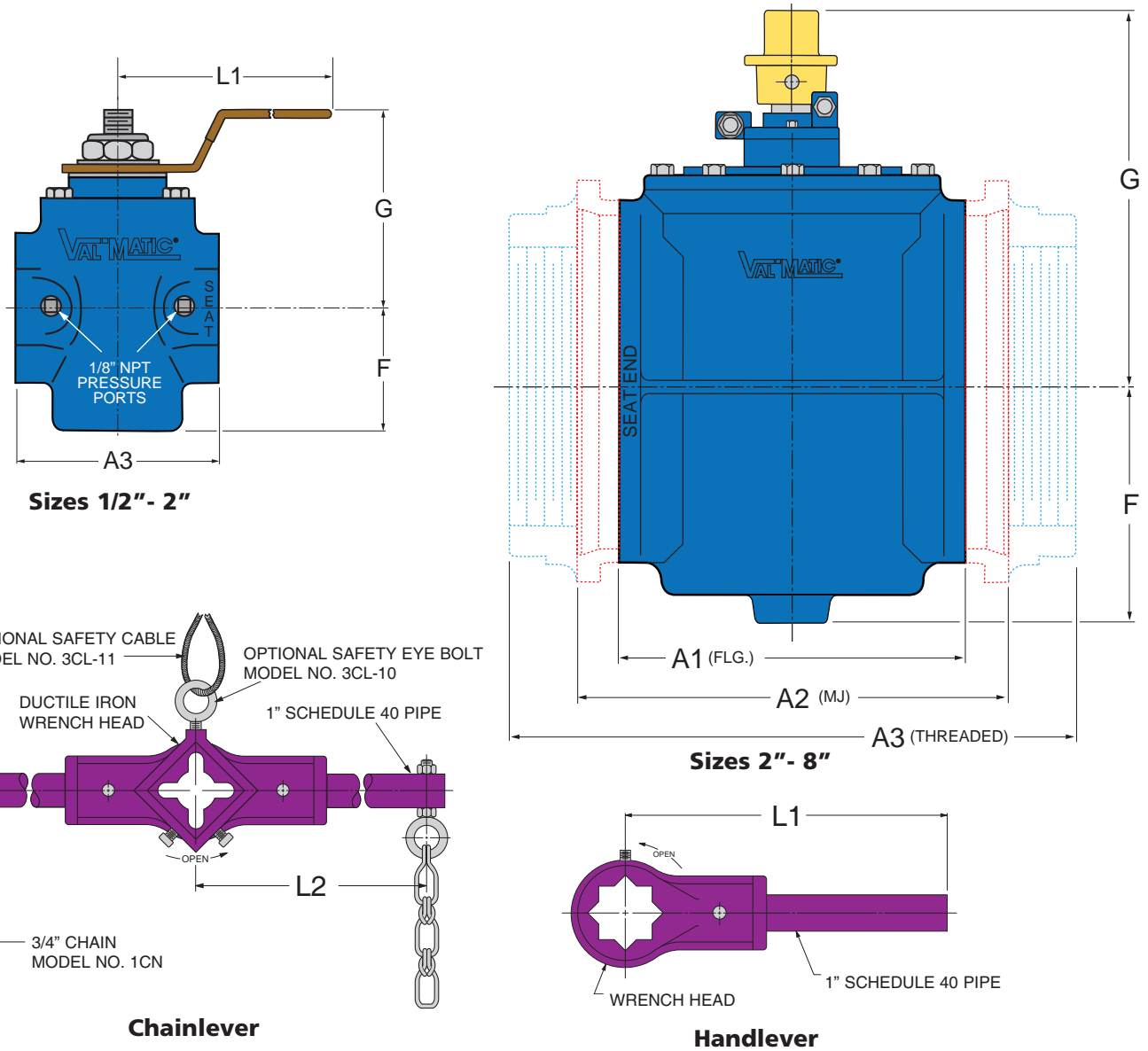

Dimensions in Inches

Valve Size	Flanged Model No.	MJ Model No.	Threaded Model No.	Handlever Model No.	Chainlever Model No.	Reverse	Direct	A1	A2	A3	F	G	L1	L2
1/2	-	-	5800.5RTL	Std	-	175	175			4.13*	1.88	3.19	4.25	-
3/4	-	-	5800.75RTL	Std	-	175	175			4.13*	1.88	3.19	4.25	-
1	-	-	5801RTL	Std	-	175	175	-	-	3.13	1.88	3.19	4.25	-
1 1/4	-	-	5801.25RTL	Std	-	175	175			6.75*	2.88	4.25	6.50	-
1 1/2	-	-	5801.5RTL	Std	-	175	175			6.75*	2.88	4.25	6.50	-
2	5802RN	-	5802RTL	Std	-	175	175	7.50	-	5.25	2.88	4.25	6.50	-
2 1/2	5825RN	-	5825RTN	4L	3CL	175	175	7.50	-	8.75	4.63	10.00	22.00	16.00
3	5803RN	5903RN	5803RTN	4L	3CL	175	175	8.00	11.50	8.75	4.63	10.00	22.00	16.00
4	5804RN	5904RN	-	4L	4CL	175	175	9.00	14.25	-	5.56	10.93	22.00	22.00
6	5806RN	5906RN	-	8L	6CL	50	100	10.50	15.75	-	7.06	12.31	44.00	32.00
8	5808RN	5908RN	-	8L	8CL	50	100	11.50	17.25	-	8.75	13.88	44.00	44.00

*Asterisk indicates length includes reducing bushing.

Notes: 1. Flange drilling conforms to ANSI B16.1, Class 125.

2. Mechanical Joint (MJ) Ends conform to ANSI/AWWA C110/A21.10.

3. Threaded Ends conform to ANSI/ASME B1.20.1.

4. Handlevers (i.e. 4L) Chainlevers (i.e. 3CL) and Chain (1CN) are ordered separately.

Installation Dimensions

Standard Port

Flanged & Mechanical Joint End Connections

Series 5800R & 5800HP Flanged

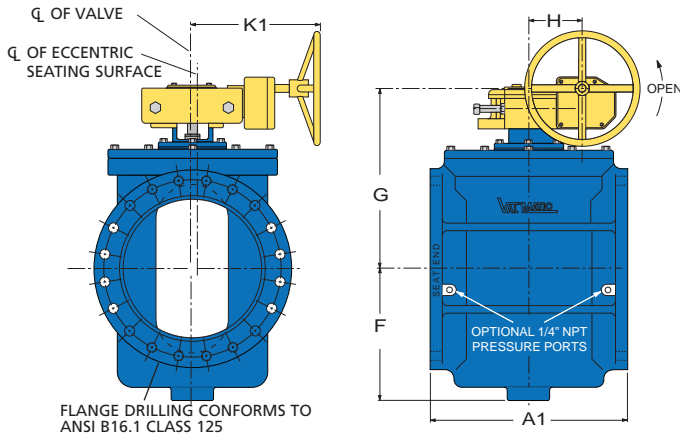

Series 5900R & 5900HP Mechanical Joint

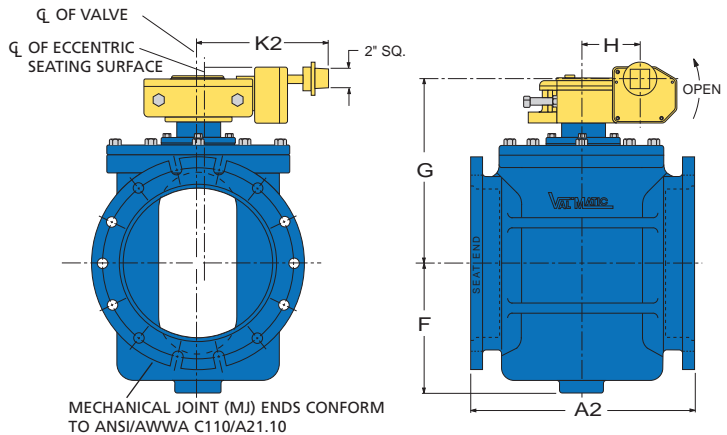

Dimensions in Inches

Valve Size	Flanged Model No.	MJ Model No.	Reverse	Direct	A1	A2	F	G	H	K1	K2
2 1/2	5825R/7A08*	-	175	175	7.50	-	4.50	7.50	3.06	9.50	-
3	5803R/7A08*	5903R/8A02A*	175	175	8.00	11.50	4.50	7.50	3.06	9.50	9.00
	5803HP/7A08*	5903HP/8A02A*	250	250							
4	5804R/7A08*	5904R/8A02*	175	175	9.00	14.00	5.56	9.31	3.06	9.50	9.00
	5804HP/7A08*	5904HP/8A02*	250	250						11.63	
6	5806R/7A08*	5906R/8A02*	175	175	10.50	15.75	7.06	11.06	3.06	9.50	9.00
	5806HP/7A12*	5906HP/8A02*	250	250						13.63	
8	5808R/7A12*	-	100	175	11.50	17.25	8.75	12.62	3.06	11.50	9.00
	5808R/7B16*	5908R/8A02*	175	175						9.38	
	5808HP/7B18*	5908HP/8A02*	250	250							
10	5810R/7C12*	5910R/8C02*	100	175	13.00	18.75	10.44	16.25	4.75	13.13	7.88
	5810R/7D16*	5910R/8D02*	175	175						11.00	
	5810HP/7D16*	5910HP/8D02*	250	250							
12	5812R/7C16*	5912R/8C02*	100	175	14.00	19.75	12.50	17.69	4.75	11.00	7.88
	5812R/7D24*	5912R/8D02*	175	175						16.75	
	5812HP/7D24*	5912HP/8D02*	250	250							
14	5814R/7E18*	-	50	100	17.00	24.50	13.00	19.31	5.62	15.25	13.00
	5814R/7G12	5914R/8F02*	150	150				21.25	9.69	14.00	
	5814HP/7G12	5914HP/8F02*	250	250							
16	5816R/7E24*	-	50	100	17.75	24.75	14.50	20.62	5.62	17.12	13.00
	5816R/7G14	5916R/8F02*	150	150				22.56	9.69	14.62	
	5816HP/7G18	5916HP/8F02*	250	250				15.62			
18	5818R/7J30*	-	50	100	21.50	28.50	16.25	22.25	5.62	18.62	14.50
	5818R/7L24	5918R/8K02	150	150				25.12	7.38	19.25	
	5818HP/7L24	5918HP/8K02	250	250							
20	5820R/7M18	-	50	100	23.50	30.50	17.50	26.25	7.38	19.00	14.50
	5820R/7P30	5920R/8K02.5	150	150						21.88	
	5820HP/7P30	5920HP/8K02.5	250	250							
24	5824R/7M24	-	50	100	30.00	37.00	20.25	29.00	7.38	19.25	14.50
	5824R/7Q36	5924R/8K02.5	150	150					11.50	23.25	
	5824HP/7Q36	5924HP/8K02.5	250	250							
30	5830R/7R24	-	50	100	37.50	45.50	24.00	31.00	4.06	16.12	14.44
	5830R/7T30	5930R/8S02	150	150							
36	5836R/7S30	-	50	100	52.00	60.00	29.00	31.00	4.06	16.12	14.44
	5836R/7W36	5936R/8T02	150	150				32.25	10.50	23.50	
42	5842R/7X30	-	50	100	62.00	70.00	36.50	44.00	14.00	25.25	27.60
	5842R/7Z36	5942R/8Z02	150	150							
48	5848R/7X30	-	50	100	84.00	84.00	38.50	48.46	10.90	27.60	27.60
	5848R/7Z36	5948R/8Z02	150	150							
54	5854R/7X30	-	50	100	96.00	-	38.50	48.46	10.90	27.60	-
	5854R/7Z36	-	150	150							
60	Consult Factory										

*Asterisk indicates valve model numbers without spur gear

Notes: 1. Replace Handwheel (HW) diameter in the model number (i.e. /7A08) with 02 for 2" square operating nut (i.e. /7A02).

2. Add a C suffix to model number to include Chainwheel Kit (i.e. 5804R/7A08C).

3. Available with ISO/PN drilling.

Installation Dimensions

100% Port

Flanged & Mechanical Joint End Connections

Series 5600R Flanged

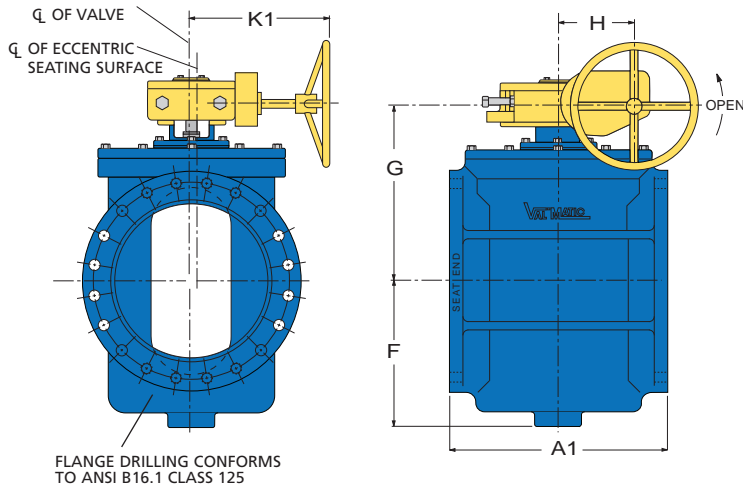

Series 5700R Mechanical Joint

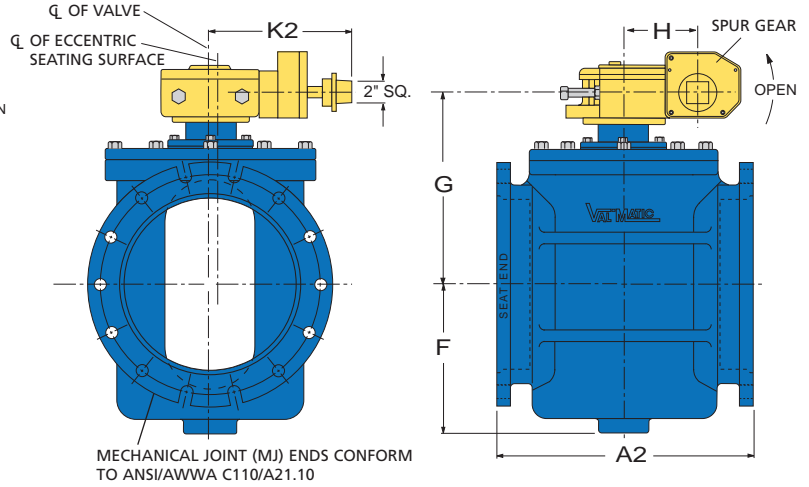

Dimensions in Inches

Valve Size	Flanged Model No.	MJ Model No.	Reverse	Direct	A1	A2	F	G	H	K1	K2
3	5803R/7A08*	5903R/8A02A*	175	175	8.00	11.50	4.50	7.50	3.06	9.50	9.00
4	5804R/7A08*	5904R/8A02*	175	175	9.00	14.00	5.56	9.31	3.06	9.50	9.00
6	5606R/7A12*	-	100	175	13.50	19.00	8.75	12.63	3.06	9.38	10.81
	5606R/7B16*	5706R/8A02*	175	175							
8	5608R/7C12*	5708R/8C02*	100	175	18.00	23.75	10.44	16.25	4.75	9.69	10.81
	5608R/7D16*	5708R/8D02*	175	175							
10	5610R/7C16*	5710R/8C02*	100	175	17.00	22.75	12.25	17.69	4.75	9.69	10.81
	5610R/7D24*	5710R/8D02*	175	175							
12	5612R/7E18*	-	50	100	21.63	27.25	13.00	19.31	5.63	15.25	13.00
	5812R/7G12	5712R/8F02*	150	150				21.25	9.69	14.00	
14	5614R/7E24*	-	50	100	22.50	30.00	14.50	20.63	5.63	17.13	13.00
	5614R/7G14	5714R/8F02*	150	150				22.56	9.69	14.63	
16	5616R/7J30*	-	50	100	21.50	28.50	16.25	22.25	5.63	18.63	12.63
	5616R/7L24	5716R/8K02	150	150				24.31	9.69	16.75	
18	5618R/7M18	-	50	100	23.50	30.50	17.50	25.50	9.69	15.50	12.63
	5618R/7P30	5718R/8K02	150	150						18.25	
20	5620R/7M24	-	50	100	42.00	49.00	20.25	28.31	9.69	16.75	12.63
	5620R/7P36	5720R/8K02	150	150						19.25	
24	5624R/7R24	-	50	100	42.00	49.00	24.00	31.00	4.06	16.13	14.44
	5624R/7T36	5724R/8S02	150	150							
30	5630R/7S30	-	50	100	52.00	60.00	29.00	31.00	4.06	16.13	14.44
	5630R/7W30	5730R/8T02	150	150				32.25	10.50	23.50	
36	5636R/7X30	-	50	75	60.00	60.00	36.50	42.00	10.50	21.75	21.75
	5636R/7Z18	5736R/8Z02	150	150				44.00	14.00	25.25	
42	5642R/7Z30	-	50	100	84.00	94.00	38.13	48.46	10.90	36.32	27.60
	-	5742R/8Z02	150	150							
48	5648R/7X30	-	50	100	84.00	84.00	38.13	48.46	10.90	36.32	27.60
	-	5748R/8Z02	150	150							
54	Consult Factory										
60	Consult Factory										

*Asterisk indicates valve model numbers without spur gear

- Notes:
1. Replace Handwheel (HW) diameter in the model number (i.e. /7A08) with 02 for 2" square operating nut (i.e./7A02).
 2. Add a C suffix to model number to include Chainwheel Kit (i.e. 5606R/7A12C).
 3. Available with ISO/PN drilling.

3-Way/4-Way Tapered Plug Valves

The Val-Matic 3-Way and 4-Way Plug Valves are of the resilient seated type with a concentric acting tapered plug. The concentric action allows the plug to rotate through various positions as needed for use with standard gears without the need for lifting the plug during actuation. The tapered seat and the adjustable plug assures tight shut-off service in the most severe service such as sewage, industrial waste and slurries.

The valves are designed for throttling and diverting applications and can be arranged in a number of flow combinations. They can be used in clean water, solid-laden water, viscous liquids, sludge, abrasive and fibrous slurries.

Special Features:

- **100% Port Area:** Assures low headloss while providing expanded passage way for solids, minimizing the chance of clogging.
- **Conforms to Standard Tee and Cross Dimensions:** Allows simplified piping layouts and easy installation into existing piping systems.
- **Externally Adjustable Plug:** The 2-way thrust bearing design positions the plug in the seat for positive shut off with low operating torque.
- **Ductile Iron Construction:** Provides superior strength and corrosion resistance in a light weight smaller valve.
- **Fusion Bonded Epoxy:** Interior and exterior FBE coated for maximum durability, corrosion resistance and low headloss.
- **Radial Bearings:** Heavy duty T316 Stainless Steel and permanently lubricated for long life and lower operating torque.
- **Pop™ Shims:** Packing Overload Protection Shims protect packing by preventing overload during field adjustment.
- **Plug:** Fully rubber encapsulated molded plug eliminates exposed surfaces preventing corrosion and delamination.
- **O-Ring Type Seating:** Raised sealing bead on molded plug assures positive seating and low operating torque.
- **Grit-Guard™ Shaft Seals:** Extends life of V-Type packing, plug shaft and bearings.
- **Optional Welded Nickel Seating:** Provides long life in the most severe service applications.

Flow Configurations

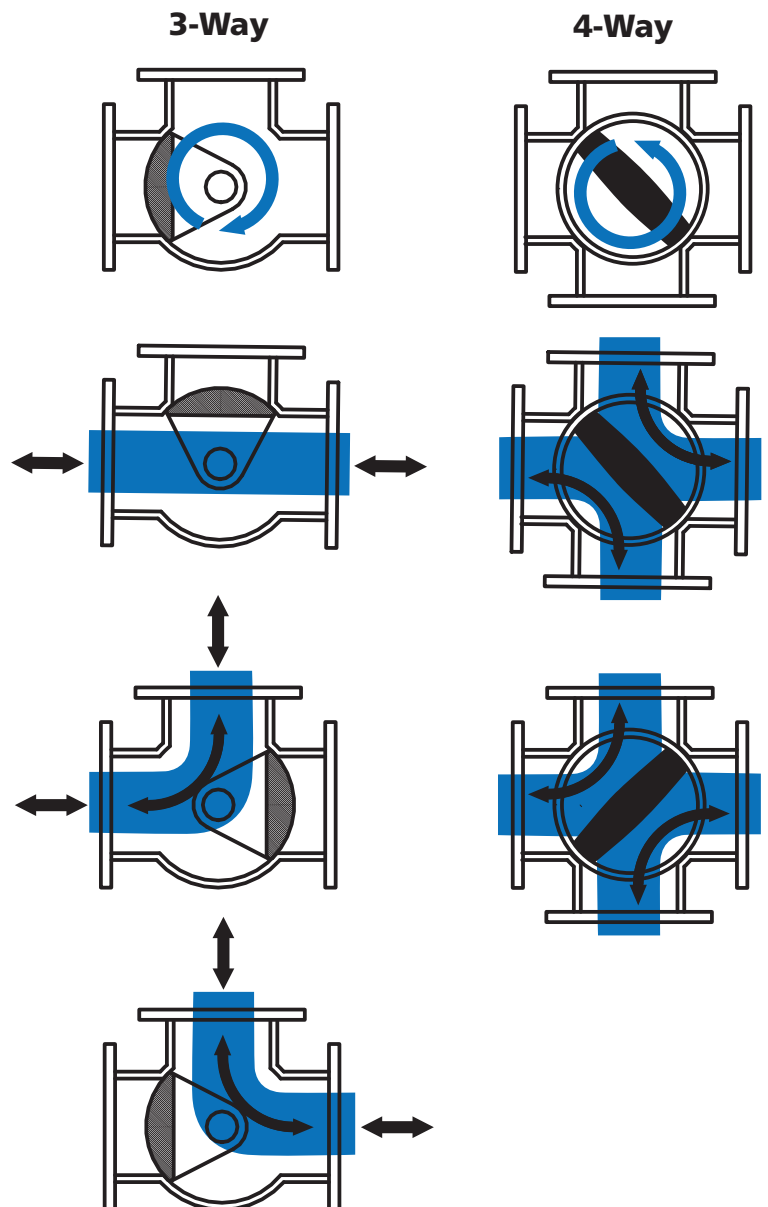

Installation Dimensions

3-Way Tapered Plug Valve

Series 5500 Flanged

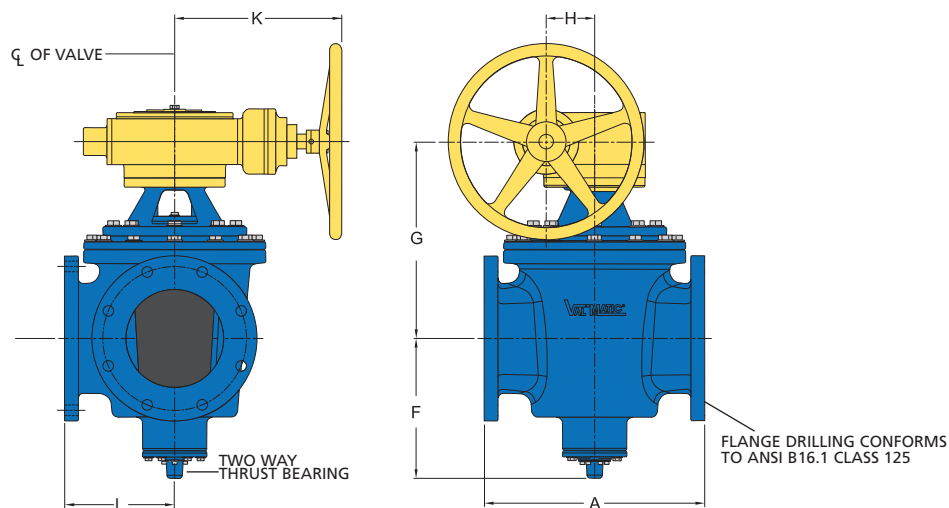

Dimensions in Inches									
Valve Size	Model No.	90° Gear Model	360° Gear Model	A*	F	G	H	K	L*
4	5504	7A12	7B12	13.00	8.25	10.24	2.50	9.20	6.50
6	5506	7C18	7D18	16.00	9.50	13.90	3.90	13.30	8.00
8	5508	7E16	7F16	18.00	11.44	15.72	3.90	15.20	9.00
10	5510	7G24	7H24	22.00	12.44	17.22	4.90	17.70	11.00
12	5512	7J24	7K24	24.00	13.88	18.97	4.90	17.60	12.00

*Conforms to standard Tee Fittings in accordance with ANSI B16.1.

Installation Dimensions

4-Way Tapered Plug Valve

Series 5400 Flanged

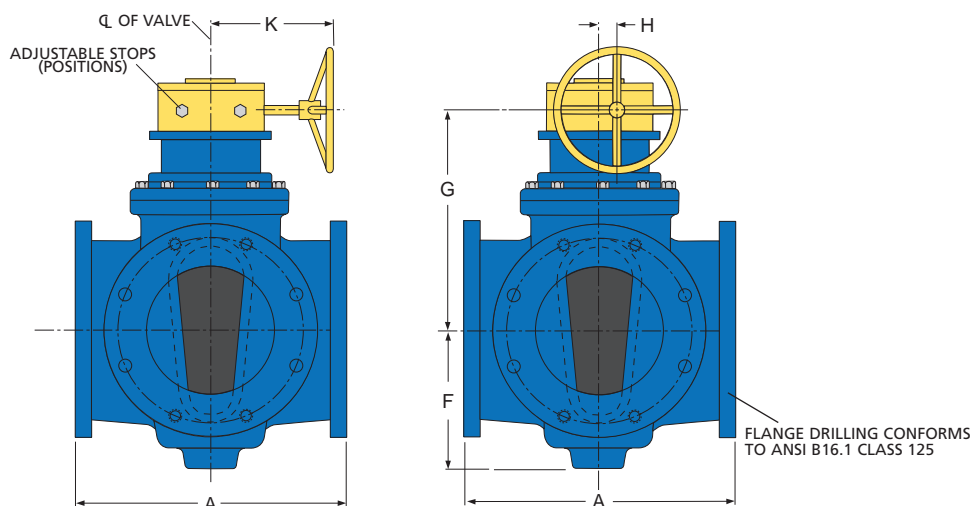

Dimensions in Inches						
Valve Size	Model No.	A*	F	G	H	K
4	5404/9A08	13.00	6.75	12.25	3.06	10.81
6	5406/9A08	16.00	8.00	14.13	3.06	10.81
8	5408/9A12	18.00	9.75	15.50	3.06	10.81
10	5410/9A12	22.00	12.75	19.75	4.90	12.50
12	5412/9B24	24.00	13.00	20.25	4.90	12.50

*Conforms to standard Cross Fittings in accordance with ANSI B16.1.

Flow Characteristics

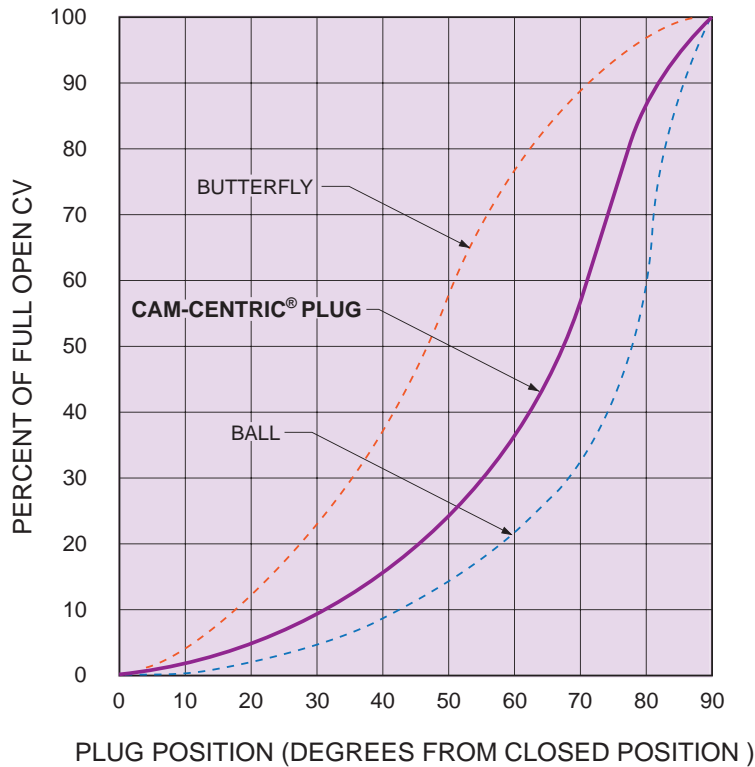

INHERENT PUMP CONTROL FLOW CHARACTERISTICS

To control pressure surges and provide good-controllability, the flow characteristics of valves should be considered.

The graph at left shows the inherent flow characteristics at a constant ΔP for various valves.

The Plug Valve has an inherent flow characteristic similar to a ball valve. When installed in a pipeline, the plug valve will approximate a linear flow characteristic because the piping system pressure losses will shift the flow curve to the left. A linear installed flow characteristic will help control surges and provide a wide range of controllability.

Installations



Cam-Centric® Plug Valve with worm gear actuator and chainwheel

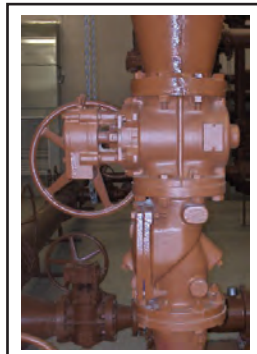

Cam-Centric® Plug Valve with Val-Matic Swing-Flex®



3-Way Cam-Centric® Plug Valves with worm gear actuators



Cam-Centric® Plug Valve with motor actuator



Cam-Centric® Plug Valve with worm gear actuator

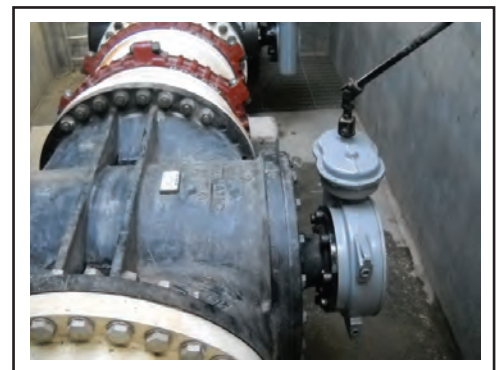

Cam-Centric® Plug Valve with worm gear actuator and extension stem

2-Way Specification

SCOPE

- 1.1 This specification covers the design, manufacture, and testing of 1/2 in. (15 mm) through 3 in. (80 mm) Threaded Eccentric Plug Valve, 2 1/2 in. (60 mm) through 60 in. (1500 mm) Eccentric Plug Valve, and 4 in. (100 mm) through 60 in. (1500 mm) 100% Port Eccentric Plug Valve suitable for water or wastewater service with pressures up to 250 psig (1725 kPa).
- 1.2 Plug Valves shall be quarter-turn, non-lubricated with resilient encapsulated plug.

STANDARDS AND APPROVALS

- 2.1 2 1/2 in. (60 mm) through 60 in. (1500 mm) plug valves shall be designed, manufactured and tested in accordance with American Water Works Association Standard ANSI/AWWA C517.
- 2.2 All Plug Valves shall be certified Lead-Free in accordance with NSF/ANSI 372.
- 2.3 Manufacturer shall have a quality management system that is certified to ISO 9001 by an accredited, certifying body.

CONNECTIONS

- 3.1 Threaded valves shall have threaded NPT full size inlets. The connection shall be hexagonal for a wrench connection.
- 3.2 Flanged valves shall have flanges with drilling to ANSIB16.1, Class 125.
- 3.3 Mechanical Joint valves shall fully comply with ANSI/AWWA C111/A21.11.

DESIGN

- 4.1 Threaded and all other valves under 4" (100mm) shall have port areas of not less than 100% of pipe area. Port areas on other sizes are 85% on 16" (400 mm) and smaller, 80% on 18"-24" (150 mm- 600 mm), and 75% on 30" (800 mm) and larger.
- 4.2 Threaded valve seat shall be a machined seating surface.
- 4.3 2 1/2 in. (60 mm) through 60 in. (1500 mm) plug valves shall have a valve seat that is a welded overlay of 95% pure nickel applied directly to the body on a pre-machined, cast seating surface and machined to a smooth finish.
- 4.4 Threaded valves shall have shaft seals which consist of V-type lip seal in a fixed gland with a resilient O-ring spring.
- 4.5 2 1/2 in. (60 mm) through 60 in. (1500 mm) plug valves shall have shaft seals which consist of V-type packing in a fixed gland with an adjustable follower designed to prevent over compression of the packing and to meet design parameter of the packing manufacturer. Removable POP™ shims shall be provided under the follower flanges to provide for adjustment and prevent over tightening.
- 4.6 Permanently lubricated, radial shaft bearings shall be supplied in the upper and lower bearing journals. Thrust bearings shall be provided in the upper and lower journal areas, except for threaded type which only have upper thrust bearings.
- 4.7 Both the packing and bearings in the upper and lower journals shall be protected by a Grit-Guard™ "drip tight" Buna-N shaft seal located on the valve shaft to minimize the entrance of grit into the bearing journal and shaft seal areas.
- 4.8 The threaded valve body shall have 1/8" NPT upstream and downstream pressure ports.

MATERIALS

- 5.1 Valve bodies and covers shall be constructed of ASTM A126 Class B cast iron for working pressures up to 175 psig (1200 kPa) and ASTM A536 Grade 65-45-12 for working pressures up to 250 psig (1725 kPa). The words "SEAT END" shall be cast on the exterior of the body seat end.
- 5.2 Threaded valve plugs in sizes 1/2 in. (15 mm) through 3 in. (80 mm) shall be of one-piece construction and made of ASTM A126 Class B cast iron fully

- encapsulated with a resilient facing per ASTM D2000-BG and ANSI/AWWA C517 requirements.
- 5.3 2 1/2 in. (60 mm) through 60 in. (1500 mm) plugs shall be of one-piece construction and made of ASTM A126 Class B cast iron or ASTM A536 Grade 65-45-12 ductile iron and fully encapsulated with resilient facing per ASTM D2000-BG and ANSI/AWWA C517 requirements.
- 5.4 Threaded valves shall have radial shaft bearings constructed of self-lubricating Type 316 stainless steel. The top thrust bearing shall be Teflon.
- 5.5 2 1/2 in. (60 mm) through 60 in. (1500 mm) plug valves shall have radial shaft bearings constructed of self-lubricating Type 316 stainless steel. The top thrust bearing shall be Teflon. The bottom thrust bearing shall be self-lubricating Type 316 stainless steel. Cover bolts shall be corrosion resistant with zinc plating.

ACTUATION

- 6.1 Threaded valves shall be equipped with a hand lever with a dial indicator and open memory stop.
- 6.2 Valves 2 1/2 in. (60 mm) to 8 in. (200 mm) and 4 in. (100mm) to 6 in. (150 mm) 100% ported shall be equipped with a 2 inch square nut for direct quarter turn operation. The packing gland shall include a friction collar and an open position memory stop. The friction collar shall include a nylon sleeve to provide friction without exerting pressure on the valve packing.
- 6.3 When specified valves 4 in. (100 mm) and larger shall include a totally enclosed and sealed worm gear actuator with position indicator (above ground service only) and externally adjustable open and closed stops. The worm segment gear shall be ASTM A536 Grade 65-45-12 ductile iron with a precision bore and keyway for connection to the valve shaft. Bronze radial bearings shall be provided for the segment gear and worm shaft. Alloy steel roller thrust bearings shall be provided for the hardened worm.
- 6.4 All gear actuators shall be designed to withstand, without damage, a rim pull of 200 lb. on the hand wheel and an input torque or 300 ft.-lbs. for nuts.
- 6.5 Buried service actuators shall be packed with grease and sealed for temporary submergence to 20 feet of water. Exposed worm shafts shall be stainless steel.

OPTIONS

- 7.1 When specified, the valve port area shall have not less than 100% of pipe area.
- 7.2 The interior and exterior of the valve shall be coated with an NSF/ANSI 61 approved fusion bonded epoxy.
- 7.3 The interior of the valve shall be coated with 8 mils SG-14 glass lining or 1/8" soft rubber lining.

MANUFACTURE

- 8.1 Manufacturer shall demonstrate a minimum of ten (10) years' experience in the manufacture of plug valves. When requested, the manufacturer shall provide test certificates, dimensional drawings, parts list drawings and operation and maintenance manuals.
- 8.2 The exterior of the valve for above ground service shall be coated with a universal alkyd primer. Valve exterior for buried service shall be coated with an epoxy coating.
- 8.3 Valve shall be marked with the Serial Number, Manufacturer, Size, Cold Working Pressure (CWP) and the Direct and Reverse Actuator Pressure Ratings on a corrosion resistant nameplate.
- 8.4 Plug Valves shall be Series # 5600R (100% Port Flanged), 5700R (100% Port Mechanical Joint), 5800RTL (Threaded), 5800R (Flanged), 5800HP (Flanged), 5900R (Mechanical Joint) or 5900HP (Mechanical Joint) as manufactured by Val-Matic Valve and Mfg. Corporation, Elmhurst, IL. USA or approved equal.

3-Way/4-Way Specification

SCOPE

- 1.1 This specification covers the design, manufacture, and testing of 4 in. (100 mm) through 12 in. (300 mm) 3-Way 100% Ported Tapered Plug Valves and 4 in. (100 mm) through 12 in. (300 mm) 4-Way 100% Ported Tapered Plug Valves suitable for water or wastewater service with pressures up to 175 psig (1200 kPa) or 250 psig (1725 kPa) when specified.
- 1.2 Plug Valves shall be concentric, non-lubricated with resilient encapsulated plugs capable of 90, 180 and 360 degree worm gear actuator.

STANDARDS AND APPROVALS

- 2.1 The valves shall be certified to be Lead-Free in accordance with NSF/ANSI 372.
- 2.2 Manufacturer shall have a quality management system that is certified to ISO 9001 by an accredited, certifying body.

CONNECTIONS

- 3.1 Flanged 3-Way and 4-Way valves shall have flange drilling and face-to-face dimensions in accordance with ANSI B16.1 Class 125 for standard Tee and Cross Fittings.

DESIGN

- 4.1 Port areas shall be not less than 100% of pipe area.
- 4.2 The valve seat shall be a machined taper in the body concentric to the valve shaft.
- 4.3 Shaft seals shall consist of V-type packing in a fixed gland with an adjustable follower designed to prevent over compression of the packing and to meet design parameters of the packing manufacturer. Removable POP™ shims shall be provided under the follower flanges to provide for adjustment and prevent over tightening.
- 4.4 Permanently lubricated, shaft bearings shall be supplied in the upper and lower bearing journals. An externally adjustable 2-way thrust bearing shall be provided.
- 4.5 Both the packing and bearings in the upper and lower journals shall be protected by a Grit-Guard™ shaft seal located on the valve shaft to minimize the entrance of grit into the bearing journal and shaft seal areas.

MATERIALS

- 5.1 The 3-Way and 4-Way valve bodies and covers shall be constructed of ASTM A536 Grade 65-45-12 ductile iron.
- 5.2 The plug shall be of one-piece construction and constructed of ASTM A536 Grade 65-45-12 ductile iron. The plug shall be fully encapsulated with precision molded resilient material with integral wear compensating O-ring type sealing surfaces. The encapsulated material shall be Buna-N per ASTM D2000-BG and ANSI/AWWA C517 requirements or as specified.
- 5.3 Radial bearings shall be constructed of self-lubricating type 316 stainless steel. The 2-way thrust bearing shall be bronze.

ACTUATION

- 6.1 Valves shall include a totally enclosed and sealed worm gear actuator with position indicator for either 90, 180, or 360 degree operation depending on the flow configuration. The worm segment gear shall be ASTM A536 Grade 65-45-12 ductile iron with a precision bore and key way for connection to the valve shaft. Bronze radial bearings shall be provided for the segment gear and worm shaft.
- 6.2 All gear actuators shall be designed to withstand, without damage, a rim pull of 200 lb. on the hand wheel.

OPTIONS

- 7.1 When specified, the valve seats shall be a welded overlay of 95% pure nickel applied directly to the body on a pre-machined seating surface and machined to a smooth finish.

MANUFACTURE

- 8.1 The manufacturer shall demonstrate a minimum of ten (10) years' experience in the manufacture of plug valves. When requested, the manufacturer shall provide test certificates, dimensional drawings, parts list drawings and operation and maintenance manuals.
- 8.2 The interior and exterior of the valve shall be coated with an NSF/ANSI 61 approved fusion bonded epoxy.
- 8.3 Valves shall be marked with the Serial Number, Manufacturer, Size, Cold Working Pressure (CWP) on a corrosion resistant nameplate.
- 8.4 3-Way Tapered Plug Valves shall be Series 5500 and 4-Way Tapered Plug Valves shall be series 5400 as manufactured by Val-Matic Valve and Mfg. Corporation, Elmhurst, IL. USA or approved equal.

VAL-MATIC®

Val-Matic's quality of design and meticulous workmanship has set the standards by which all others are measured. Quality design features such as the AWWA **Ener•G® Ball Valve** with its energy efficient design, fusion bonded epoxy and adjustable resilient seating....**Cam-Centric® Plug Valves** have more requested features than any other eccentric plug valve....**American-BFV® Butterfly Valves** include a field replaceable seat without the need for special tools....**Tilted Disc® Check Valves** with high strength and wear resistant aluminum bronze trim as standard....**Silent Check Valves** featuring combined resilient/metal-to-metal seating and are **NSF/ANSI 61 & 372 Certified**....**Sure Seal Foot Valves** provided with a heavy duty stainless steel screened inlet....**Swing-Flex® and Surgebuster® Check Valves** designed with an unrestricted full flow area....**Swing Check Valves** with field adjustable closure versatility....**Dual Disc® Check Valves** utilizing stabilized components to provide extended life....**Air Release, Air/Vacuum and Combination Air Valves** provided standard with Type 316 stainless steel trim....**VaultSafe®** family of products includes the **FloodSafe® Inflow Preventer, FrostSafe®** two-way damper and the **VentSafe®** vent pipe security cage. These features coupled with our attention to detail put Val-Matic Valves in a class by themselves. All products are WQA certified Lead-Free in accordance with NSF/ANSI 372.

Val-Matic is totally committed to providing the highest quality valves and outstanding service to our customers. Complete customer satisfaction is our goal.

Make the Change
to Quality!

Specify

VAL-MATIC®

Val-Matic Valve and Manufacturing Corp.
905 Riverside Drive, Elmhurst, IL 60126
Phone: 630-941-7600 Fax: 630-941-8042
www.valmatic.com
valves@valmatic.com

Copyright © 2012 Val-Matic Valve & Mfg. Corp.
ISO 9001:2008 certified company